

ARTERIOCYTE

Helping Patients Heal Faster.™

MAGELLAN®

Autologous Platelet Separator System Including
Associated Disposables

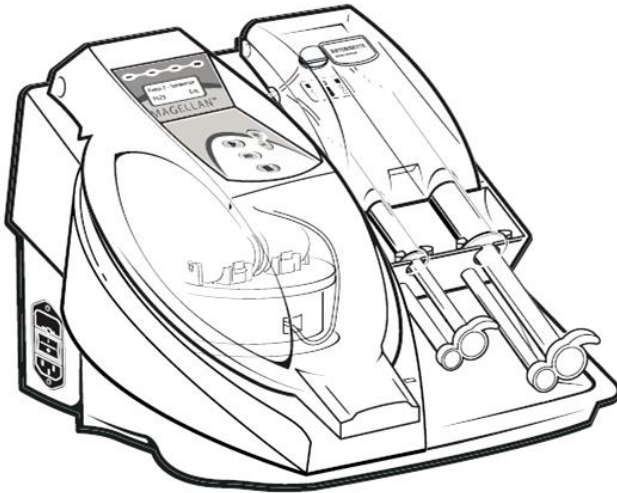

Operator's Manual

Explanation of Symbols



TUV Rheinland



Caution, Consult Accompanying Documents



Consult Instructions for Use



Federal law (USA) restricts this device to sale by or on the order of a physician



On (Power)



Off (Power)



Start/Select menu option



Stop/Back to previous menu

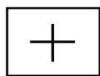

Increase platelet rich plasma (PRP) volume/Scroll up in menu

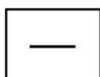

Decrease platelet rich plasma (PRP) volume/Scroll down in menu



Platelet poor plasma (PPP) collection



Fuse

Explanation of Symbols



Dangerous Voltage



Potential Equalization Conductor



Alternating Current



Date of Manufacture



Sterile Fluid Pathway



Latex Free



Nonpyrogenic



Catalog Number



Serial Number



Lot Number



Use by



Do Not Reuse



Temperature Limitation

Explanation of Symbols

	Humidity Limitation
	This Way Up
	Quantity
	Open Here
	Fragile, Handle with Care
	For US Audiences Only
U.S.P.	United States Pharmacopeia
	Do not dispose of this product in the unsorted municipal waste stream

Table of Contents

INTRODUCTION 1

Indications for Use 1

Disclaimer 1

Contraindications 1

System Description 2

How Supplied 2, 3

Principles of Operation 3

CAUTIONS 4

WARNINGS 5

PRECAUTIONS 6-8

TECHNICAL DESCRIPTION 8

SPECIFICATIONS AND DESCRIPTION 8

Intended Use Environment 8

System Specifications 9

Phases of Operation 10

Front of the Instrument 10

Cycle Progression Lights 11

Sensor Lights 11

Message Screen 12

Menu Mode 12, 13

User Interface Keys 13

Covers 13

Back of the Instrument 14

INSTRUCTIONS FOR USE 14

Set Up 14-22

User Options 23, 24

Instrument Operation 24

Program Selection and Change 24, 25

Cycle Initiation, Emptying and Completion 25-27

TROUBLESHOOTING 27

System Errors 27

User Intervention Conditions 28-33

Stopped Timer 33, 34

Blank Screen 34

CLEANING AND SERVICE 34

Cleaning 34, 35

Periodic Maintenance & Safety Inspection 35

Service 35

Calibration Services 36

End of Life Disposition 36

INSTRUMENT LIMITED WARRANTY (U.S.) 37, 38

DISPOSABLES KIT LIMITED WARRANTY (U.S.) 39, 40

EC DECLARATION OF CONFORMITY 41

INTRODUCTION

The Arteriocyte Medical Systems MAGELLAN® Autologous Platelet Separator System consists of a microprocessor-controlled centrifuge, syringe pumps and the necessary single-use processing components. With the Platelet Separator Instrument, platelet rich plasma (PRP) is automatically and quickly separated from anticoagulated blood and dispensed into a separate sterile syringe.

Indications for Use

The MAGELLAN® Autologous Platelet Separator system is designed to be used in the clinical laboratory or intraoperatively at point of care for the safe and rapid preparation of platelet poor plasma and platelet concentrate (platelet rich plasma) from a small mixture of blood and bone marrow. The plasma and concentrated platelets produced can be used for diagnostic tests. Additionally, the platelet rich plasma can be mixed with autograft and/or allograft bone prior to application to an orthopedic site.

Disclaimer

The platelet rich plasma prepared by this device has not been evaluated for any clinical indications. Platelet rich plasma prepared from a mixture of whole blood and bone marrow may contain higher levels of plasma free hemoglobin than platelet rich plasma prepared from whole blood.

Contraindications

The use of the Arteriocyte Medical Systems MAGELLAN® Platelet Separation System is contraindicated for a hemodynamically unstable or hypercoagulable patient.

Use of this product for pediatric patients should be approached carefully. Withdrawing blood from pediatric patients should be at a physician's specific direction with attention given to avoiding any significant reduction in the patient's blood volume.

Caution: Medications that adversely affect a patient's coagulation system may inhibit the use of platelet separation system therapy.

System Description

The Arteriocyte Medical Systems MAGELLAN® Autologous Platelet Separator System consists of:

- The Arteriocyte Medical Systems MAGELLAN® Autologous Platelet Separator Instrument.
- The Arteriocyte Medical Systems MAGELLAN® Autologous Platelet Separator Disposables Kit.

The complete system is shown in Figure 1.

Each procedure requires the use of one Arteriocyte Medical Systems' MAGELLAN® Platelet Separator Disposables Kit, which includes components necessary for a single patient platelet separation procedure. The separation chamber and associated tubing can be used with the same patient for up to three complete separation cycles.

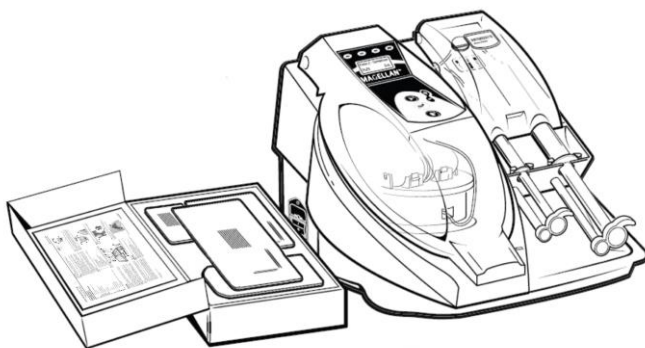

Figure 1. *The Arteriocyte Medical Systems' MAGELLAN® Autologous Platelet Separator System.*

How Supplied

The Arteriocyte Medical Systems' MAGELLAN® Autologous Platelet Separator Instrument is supplied fully assembled with one electrical power cord.

An Arteriocyte Medical Systems' MAGELLAN® Autologous Platelet Separator Disposables Kit is sold separately and is required for each procedure.

The Separator Kit is supplied in a tray and consists of the following components:

How Supplied

- One (1) separation chamber with tubing and two (2) attached luer connectors.
- One (1) 10-mL syringe (Syringe 1).
- One (1) 60-mL syringe (Syringe 2).
- One (1) 5-mL syringe.
- One (1) Needle and IV tubing.
- One (1) 50-mL of ACD-A anticoagulant.
- One (1) IV Site Prep Kit.
- One (1) 18-gauge x 3.8 cm (1.5") needle.
- Four (4) Sterile Tip Caps.

Note: If more than one separation cycle will be performed with the same patient, additional 10- mL and 60- mL syringes are required.

Principles of Operation

The Arterioocyte Medical Systems MAGELLAN® Autologous Platelet Separator Instrument operates by separating anticoagulated whole blood into individual components by centrifugation. Blood is an ideal biologic mixture for such a technique because it is a suspension of elements of significantly different densities and, thus, is easy to separate.

When subjected to a centrifugal force, the components migrate relative to their respective density, with the higher density components moving farther from the axis of rotation than those of lesser density.

With the Platelet Separator Instrument, the user can select a desired amount of platelet rich plasma (PRP), three (3) to ten (10) mL, to be

collected. The clinician also has the option of collecting platelet poor plasma (PPP) into a separate syringe after the PRP is withdrawn.

After the separation chamber is installed, and the two syringes are locked into the pumps on the front of the instrument, the separation process is automatic.

The procedure begins with syringe pump 2 activation to empty approximately 30 to 60-mL of anticoagulated blood from the

larger syringe into the centrifuge chamber while the centrifuge spins at filling speed.

When fluid is in the separation chamber, the centrifuge will spin at a higher speed, which causes heavier red blood cells (RBC) to gradually migrate to the outer ends of the chamber. The centrifuge speed will then automatically reduce, and syringe pump 2 will withdraw RBC until the sensor detects the presence of plasma at the outer ends of the chamber.

The centrifuge speed will again increase, prompting separation of platelets from the remaining plasma. Gradually a layer of platelet rich plasma is concentrated at the outer end of the chamber. Once this layer is formed, the instrument speed will reduce and a small amount of the remaining RBC in the tubing is drawn out into syringe 2. With the RBC removed, the selected volume of PRP is then withdrawn into syringe 1.

If the clinician chose to collect the platelet poor plasma (PPP), at the end of the cycle the instrument prompts the operator to replace syringe 2 with a new 60-mL syringe for PPP collection and to press the **[START]** key. It will draw the remaining PPP into syringe 2.

CAUTIONS

READ THIS OPERATOR'S MANUAL COMPLETELY PRIOR TO USING THE ARTERIOCYTE MEDICAL SYSTEMS MAGELLAN® AUTOLOGOUS PLATELET SEPARATOR SYSTEM.

- **[USA]** Federal law (USA) restricts this device to sale by or on the order of a physician.
- Actual performance results may vary depending on many in-use variables. It is important to read and understand this Operator's Manual and understand the principles of platelet separation before undertaking clinical operation of the Arterioocyte Medical Systems MAGELLAN® Autologous Platelet Separator System.
- Medications that adversely affect a patient's coagulation system may inhibit the use of a platelet separation system.

-
- The AABB Standards for Perioperative Autologous Blood Collection and Administration (6th Edition, 2015) recommends that non-red-cell components be used prior to the patient leaving the operating room or clinical procedure area. Blood components produced by this device are not intended for patient transfusion. Treat all blood and fluids using Universal Precautions for bloodborne pathogens.
 - The disposable components are STERILE and NONPYROGENIC as long as package integrity has not been violated. Do not use if package is damaged or open. Disposable components are single-patient-use. Do not re-sterilize.
 - The ACD-A anticoagulant supplied in the disposables kit is not for intravenous use. Discard the unused portion. Do not reuse. Do not use the ACD-A anticoagulant unless the solution is clear, and the seal is intact.
 - Do not restrict the flow in any tubing line. If a tubing line is inadvertently clamped or kinked during operation, pressure may build up causing failure, fluid leakage, or incomplete separation. The operator should always check the disposable kit to confirm that all tubing is free of any kinks, twists, or flat areas.
 - The centrifuge cover seal should be inspected for cuts, tears, or other defects prior to each use.
 - Safety rules related to the use of centrifuges must be followed. Do not attempt to open the centrifuge or remove the chamber before it comes to a complete stop.

WARNINGS

- To avoid the risk of electric shock, this equipment must only be connected to supply mains with protective earth.
- No modification of this equipment is allowed.
- The use of accessories, transducers and/or cables other than those specified (if applicable), with the exception of those sold by the manufacturer as replacement parts for internal components, may result in increased emissions or decreased immunity of the MAGELLAN® System.

-
- The MAGELLAN® System should not be used adjacent to or stacked with other equipment and that if adjacent or stacked use is necessary, the equipment or system should be observed to verify normal operation in the configuration in which it will be used.
 - Portable RF communications equipment (including peripherals such as antenna cables and external antennas) should be used no closer than 30 cm (12 inches) to any part of the MAGELLAN® System, including cables (power cord) specified by the manufacturer. Otherwise, degradation of the performance of this equipment could result.
 - The MAGELLAN® Autologous Platelet Separator Instrument should be placed on a flat, stable surface with adequate space to prevent interference with the functionality of the device.

PRECAUTIONS

1. The responsibility for the use of this device in all cases belongs solely to the physician ordering its use.
2. The safe operation of all platelet separator equipment requires the presence of a dedicated operator. It is the responsibility of the clinical facility to ensure that the individuals assigned to this task are properly trained in the operation of the Arteriocyte Medical Systems MAGELLAN® Autologous Platelet Separator System and be alert to potential problems. Never leave the machine unattended during operation.
3. Only Arteriocyte Medical Systems sterilized disposable kits are approved for patient use with the MAGELLAN® Autologous Platelet Separator Instrument. It is important that aseptic technique be used to minimize the possibility of contamination of the disposable components and/or patient.
4. Store all disposable components in a dry place away from extremes of environmental conditions.

-
5. The Arteriocyte Medical Systems MAGELLAN® Autologous Platelet Separator System must not be used in the presence of flammable agents.
 6. Do not use the Arteriocyte Medical Systems' MAGELLAN® Autologous Platelet Separator System at temperatures higher than 30°C (86°F). Operation at temperatures over 30°C (86°F) may cause overheating of the centrifuge, which could cause hemolysis.
 7. Materials used in the Arteriocyte Medical Systems MAGELLAN® disposable kit may be sensitive to chemicals (such as solvents and certain detergents). Under certain adverse conditions, exposure to these chemicals (including vapors) may cause the plastics to fail or malfunction. Visually inspect the contents of the disposable kit. Should any evidence of damage to the components be found during inspection or setup, do not use the disposable components. Do not use silicone oils or greases near disposable components.
 8. In the unlikely event of a power failure, operator can attempt the purge procedure to return volume back to the 60-mL syringe and restart. In the event of a failure of the instrument, the clinician must start a new procedure using new disposable components.
 9. Inside the Arteriocyte Medical Systems MAGELLAN® Autologous Platelet Separator Instrument cabinet are various electrical components and wiring. Physical contact with any of these components, while the unit is plugged in, could result in severe electrical shock. Always turn off and unplug the unit prior to working inside the cabinet or changing any fuses. For continued protection against risk of fire, replace fuses only with the same type and rating. Internal grounding is provided for safety.
Medical Electrical Equipment require special precautions regarding EMC and need to be installed and put into service according to the EMC information provided in the Operator's Manual.

-
10. Leakage current is a primary indicator of electrical shock hazard to personnel making contact with any exposed portion of the equipment. Each Arterioocyte Medical Systems' MAGELLAN® Autologous Platelet Separator Instrument is checked during the final quality inspection to verify that leakage current is less than 300 μ A. The owner or operator should have leakage current checked per the recommended service / calibration schedule, 24-months or 750 cycles whichever comes first or as required by the operating facility's biomedical engineering department's standard operating procedures or other qualified service technician. In addition, particular attention should be given to checking the leakage current and insulation after an event such as a fluid spill or major voltage surge in the power source has occurred, or after any machine repair.
 11. The device must be handled with care. Dropping or impact can adversely affect the performance of the device.
 12. It is important that the Arterioocyte Medical Systems MAGELLAN® Autologous Platelet Separator Instrument be maintained in good working order and serviced on a regular basis.
 13. Do not attempt to override/bypass any safety mechanisms. Any attempt to disable or bypass the centrifuge cover latch/lock mechanism could result in damage to the device or injury to the operator.

TECHNICAL DESCRIPTION

SPECIFICATIONS AND DESCRIPTION

Intended Use Environment

MAGELLAN® Autologous Platelet Separator Instrument must be used only in Professional Healthcare Facility Environment such as physician offices, dental offices, clinics, limited care facilities, freestanding surgical centers, freestanding birthing centers, multiple treatment facilities, hospitals (emergency rooms, patient rooms, intensive care, surgery rooms except near HF SURGICAL EQUIPMENT, outside the RF shielded room of an ME SYSTEM for magnetic resonance imaging).

System Specifications

Note: Technical data, features and options referenced in this manual are based on the latest information available at the time of printing. Arteriocyte Medical Systems reserves the right to change specifications without notice.

- **Electrical Classification:**
Class I, Ordinary, Continuous Operation.
- **Power:**
Voltage: 100–240 V~
Frequency: 50–60 Hz.
Phase: Single.
Current: 1.3 amps.
Fuses: 5 x 20mm ceramic body / 6.3 amps/ High Breaking Capacity (Ceramic).
Power cord: 2 wires plus ground (earth) connector 3-prong hospital grade.
- **Speed and Flow Rate Specifications:**
Centrifuge: 0–4,000 rpm ($\pm 5\%$).
Syringe Pump: 0–60 mL/min ($\pm 5\%$).
Separation Chamber Maximum Fluid Volume: 60 mL
Separation Chamber Maximum Fluid Density: 1.1 kg/dm³
- **Dimensions:**
Width: 47 cm (18 inches).
Height: 32 cm (13 inches).
Depth: 44 cm (17 inches).
Weight: 11 kg (24 lb.).
- **Temperature Limit:**
Operational: 10°C.
30°C (50°F–86°F).
Storage: -40°C–66°C (-40°F–150°F).
- **Humidity Range:**
Operational: 10–95% noncondensing.
Storage: 10–95% noncondensing.
- **Port:**
RS-232 (This port is to be used only by authorized service personnel).

Electromagnetic Emissions Standards and Test Levels	
Test / Standard	Compliance
Radiated Emissions CISPR 11	Group 1, Class B
AC Mains Conducted Emissions CISPR 11	Group 1, Class B
Harmonics IEC 61000-3-2	Group 1, Class B
Flicker IEC 61000-3-3	Group 1, Class B
Electromagnetic Immunity Standards and Test Levels Compliance	
Test / Standard	Compliance
Electro-Static Discharge IEC 61000-4-2	±8 kV Contact
	±15 kV Air
Radiated RF Immunity IEC 61000-4-3	3 V/m
	10 MHz-2600 MHz
	5 kHz-6 kHz
Electrical Fast Transients/Burst IEC 61000-4-4	24 kHz-24.25 kHz
	±2 kV, 100 kHz PRF
	±0.5, 1, 2 kV Line to Ground
Surge IEC 61000-4-5	±0.5, 1 kV Line to Line
	3 V 150 kHz-80 MHz
Conducted RF Immunity IEC 61000-4-6	6 V in ISM Bands 150 kHz-80 MHz
	80% AM at 1 kHz
	30 A/m, 50 or 60 Hz
Power Frequency Magnetics IEC 61000-4-8	100% drop, 0.5 periods, 0°, 45°, 90°, 135°, 180°, 225°, 270°, 315°
	100% dip, 1 period
	30% dip, 25/30 periods
Volage Interruptions IEC 61000-4-11	100% drop, 5 seconds

The Magellan® Autologous Platelet Separator does not provide essential performance. No situations have been identified where loss or degradation of device performance could result in an unacceptable risk of a clinical function.

Phases of Operation

Phase	Description
FILLING	Both ends of the centrifuge chamber fill simultaneously during the FILLING phase.
PROCESSING	The centrifuge will automatically spin at various speeds as it processes blood within the separation chamber and removes red blood cells into syringe 2.
COLLECTING	The instrument will automatically withdraw platelet rich plasma (PRP) into syringe 1 during the COLLECTING phase.
EMPTYING	At the end of the procedure the instrument will automatically progress to the EMPTYING phase in which it will draw remaining PPP into syringe 2.
PAUSE	The user has the option of pausing the cycle in order to draw platelet poor plasma (PPP) from the separation chamber into an alternate syringe.

Front of the Instrument

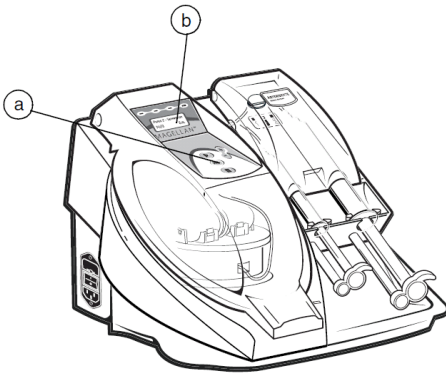

- a. user interface keys.
- b. message screen.

Figure 2. Front view of the Arterioocyte Medical Systems MAGELLAN® Autologous Platelet Separator Instrument.

Cycle Progression Lights

On the top of the centrifuge are four cycle progression lights. These will gradually illuminate through the phases of a cycle. One light will be illuminated during the FILLING phase; two during PROCESSING; three during COLLECTION, and four during the EMPTYING phase. At the end of a completed cycle all four-cycle progression lights will be illuminated.

Sensor Lights

There are four sensor lights on the front of the instrument (see Figure 3). The syringe lights are under the syringe cover but can be seen when the cover is closed. When the instrument is powered up, these four sensor lights will always be either red or green. All must be green for the instrument to function. If even one sensor light is red, the instrument will not function.

Where there is a red light, user intervention is required.

- The syringe sensor indicator lights will be red if the syringe tubing or the syringe is incorrectly placed in the syringe pump receptacle.
- The syringe and centrifuge cover indicator lights will be red if that cover is not completely closed.

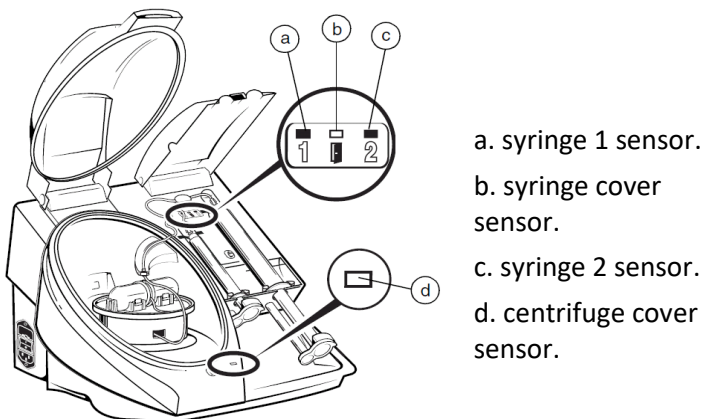

Figure 3. Four sensor lights.

Message Screen

The instrument message screen includes two lines that indicate instrument status, required user actions, cycle time remaining, and platelet rich plasma (PRP) volumes.

The top line includes text indicating instrument status and user prompts such as **[ENTER VOLUME]** (see Figure 4).

ENTER VOLUME	
00:00	5 ML

Figure 4. Message screen during a single cycle.

Before and during a separation cycle, the lower line includes a timer indicating approximate time remaining in the current cycle and the requested volume of PRP to be collected in the cycle. The time is based on the initial volume and composition of blood.

Upon completion of a cycle, the cumulative amount of PRP collected for that patient will replace the timer and be displayed on the left side of the lower line (see Figure 5).

CYCLE COMPLETE	
TOTAL: 10 ML	5 ML

Figure 5. Message screen following cumulative cycles for the same patient.

Menu Mode

Note: Menu Mode options only apply to software version 3.0 and higher.

Before a cycle is initiated, special operating programs may be selected by putting the instrument into “Menu Mode.” The programs that can be selected are:

- **PURGE:** Use to immediately purge blood out of the centrifuge into the 60-mL syringe. Once the centrifuge is purged, the unit returns to the previously selected mode (either STANDARD or MIN RBC).
- **MIN. RBC:** Increases removal of blood cells from tubing in order to minimize red blood cells in subsequent cycles.

This mode is signified by the text “– RBC” on line 2 of the display.





Note: When using this program, all cellular content will be slightly less than the standard program and cycle time will be shortened to approximately 10 minutes.

- STANDARD: The normal, general purpose operating mode.

In order to select one of the programs using the Menu Mode, do the following:

- Before a cycle has been initiated, continually press the minus (-) key until “OPTIONS” is displayed on line 2.
- Press the [START] key.
- Use the plus (+) and minus (-) keys to scroll through the options described above. When the desired option is visible, press the [START] key.

User Interface Keys

					
Normal Mode	Start	Platelet poor plasma (PPP) collection	Stop	Increase of platelet rich plasma (PRP) volume	Decrease of platelet rich plasma (PRP) volume
Menu Mode*	Select		Back	Scroll Up	Scroll down

*Menu Mode options only apply to software version 3.0 and higher.

Covers

Both the centrifuge and the syringe pump receptacles have covers which must be closed and latched prior to the beginning of a cycle of operation. When one is incorrectly closed or not properly latched, the corresponding sensor light will be red.

Take care in closing the lids as they will break if excessive force is used.

The centrifuge cover stays locked in the closed position whenever the centrifuge is spinning. Do not attempt to open the cover until the centrifuge stops spinning and the locking

mechanism releases. Never attempt to force open the machine.

Back of the Instrument

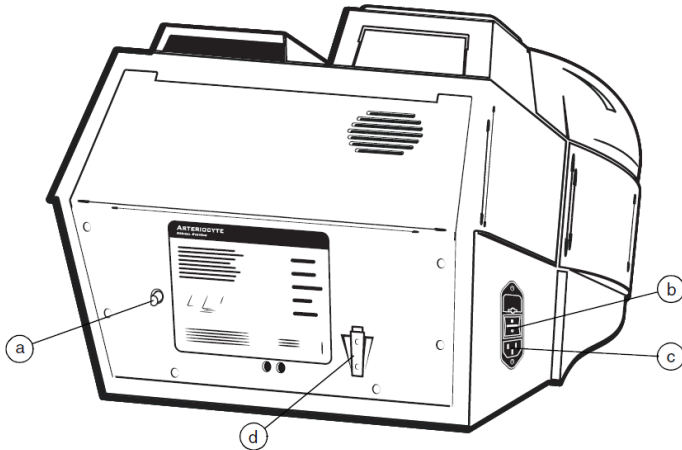

- a. volume adjustment.
- b. on/off switch.
- c. power cord port.
- d. RS-232-Serial Port (for authorized service only).

The user can adjust the volume of the audible alarms by turning the volume adjustment screw.

Figure 6. Back and side view of the Arterioocyte Medical Systems MAGELLAN® Autologous Platelet Separator Instrument.

INSTRUCTIONS FOR USE

Set Up

Equipment Required

- Arterioocyte Medical Systems MAGELLAN® Autologous Platelet Separator Instrument.
- Arterioocyte Medical Systems MAGELLAN® Autologous Platelet Separator Disposables Kit.

Components of the system are shown in Figure 7.

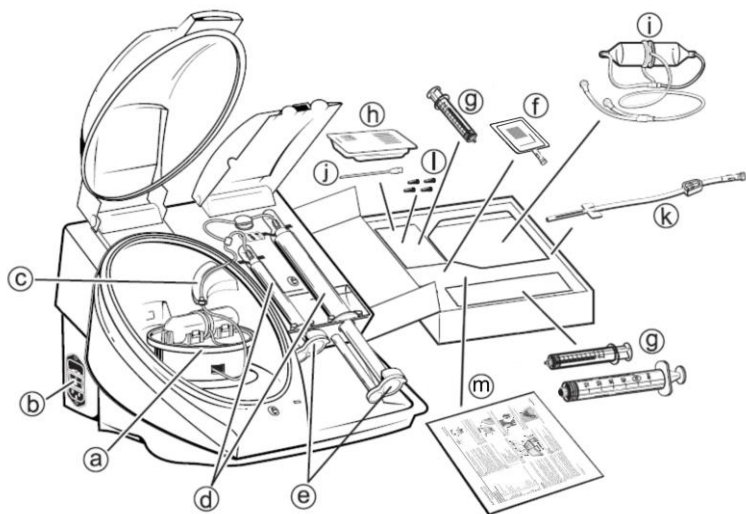

Figure 7. The Arterioocyte Medical Systems MAGELLAN® Platelet Separator Instrument and associated disposable components.

- a. centrifuge caddy.
- b. instrument power cord port, on/off switch.
- c. tubing support arm.
- d. syringe pump receptacles.
- e. plunger drivers.
- f. 50 mL of ACD-A anticoagulant.
- g. three (3) syringes (60-mL, 10-mL, 5-mL).
- h. IV Site prep kit.
- i. separation chamber with attached tubing.
- j. 18-gauge x 3.8 cm (1.5") needle.
- k. Needle and IV tubing.
- l. four syringe tip caps.
- m. Instructions for Use.

Instrument Set Up

1. Open the platelet separator instrument package and make sure the contents include one (1) machine, one (1) electrical power cord, one (1) operator's manual, one (1) quick reference guide, one (1) ACD-A label containing ACD-A/blood volume ratio configuration, and one (1) troubleshooting guide.

-
2. Set the machine on a stable surface and thoroughly inspect all components for damage.

Caution: If any instrument component is missing or damaged, do not use it. Contact your Arteriocyte Medical Systems service representative.

3. Plug the electrical power cord into the side of the instrument and into a standard electrical outlet (100–240-volt AC).
4. Turn on the instrument using the on/off switch on the side panel.
5. When the platelet separator instrument is powered on it will perform a system check during which the software version message will appear on the screen.
6. When the system test is complete, the message [**LOAD SYSTEM - ENTER VOLUME**] will appear on the message screen.
7. Open the syringe cover and the centrifuge cover and prepare an Arteriocyte Medical Systems MAGELLAN® Autologous Platelet Separator Disposables Kit as described below.

Separator Disposables Kit Set Up Note:

For platelet separation with the Arteriocyte Medical Systems MAGELLAN® Autologous Platelet Separator Instrument, an Arteriocyte Medical Systems MAGELLAN® Autologous Platelet Separator Disposables Kit is required.

Caution: All components of the disposable kits are single-patient-use. The separation chamber and associated tubing can be used with the same patient for up to three complete separation cycles. Do not re-sterilize.

Caution: Do not use the kit if any component or the tray is damaged or open.

Contents of the Arteriocyte Medical Systems MAGELLAN® Autologous Platelet Separator Disposables Kit:

- One (1) separation chamber with attached tubing and luer connectors.
- One (1) 10-mL syringe (Syringe 1).
- One (1) 60-mL syringe (Syringe 2).

-
- One (1) 5-mL syringe.
 - One (1) Needle and IV tubing.
 - One (1) 50-mL of ACD-A anticoagulant.
 - One (1) IV Site Prep Kit.
 - One (1) 18-gauge x 3.8 cm (1.5") needle.

Note: If more than one separation cycle will be performed with the same patient, additional 10-mL and 60-mL syringes are required.

1. Remove the cover from the separator disposables kit tray.
2. Be certain that all components are present and undamaged.
3. Remove the separation chamber package from the tray.
4. Peel open the lid on the chamber package.
5. Holding the platelet separation chamber with the vent facing upward, thread the attached tubing through the center of the chamber caddy (see Figure 8a and b).

Caution: If resistance is experienced, DO NOT pull on the tubing.

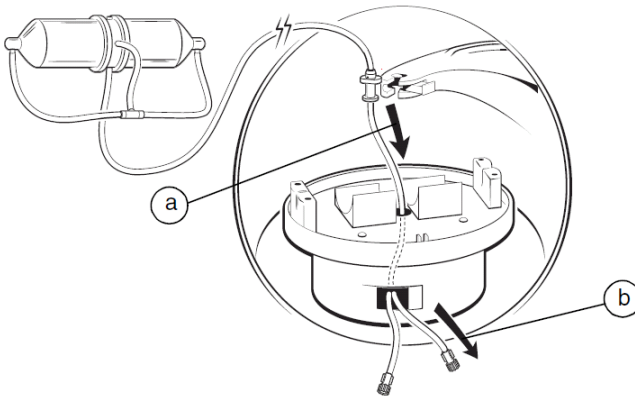

Figure 8. Thread the separation chamber tubing through the center of the chamber caddy.

6. Install the platelet separation chamber into the centrifuge caddy making certain that both ends of the chamber are properly located in the caddy notches (see Figure 9a). Place T-connector in slot (see Figure 9b), and tubing under retainer on top surface of caddy (see Figure 9c). Press

tubing down into groove on outer edge of chamber caddy (see Figure 9d).

Caution: Failure to install the separation chamber properly may result in error codes.

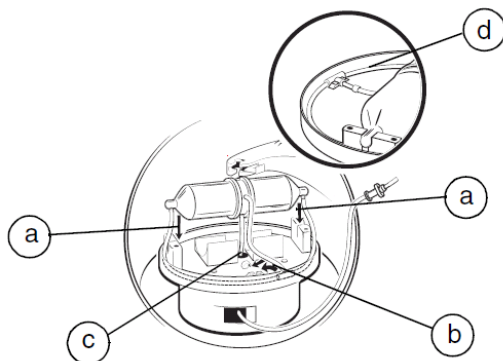

Figure 9. Install the separation chamber into the caddy and place tubing into slot and under retainer.

7. Rotate the tubing collar so that its shape aligns with the opening in the support arm. Slide the tubing collar into the support arm (see Figure 10a) and close the latch (see Figure 10b).

Caution: Make certain all tubing is free of any kinks, twists, or flat areas.

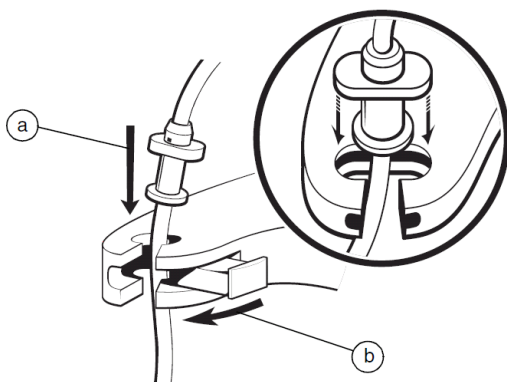

Figure 10. Attach chamber tubing collar to instrument tubing support arm.

-
8. Press tubing down into groove on support arm and place tubing through notch in centrifuge ridge (see Figure 11).

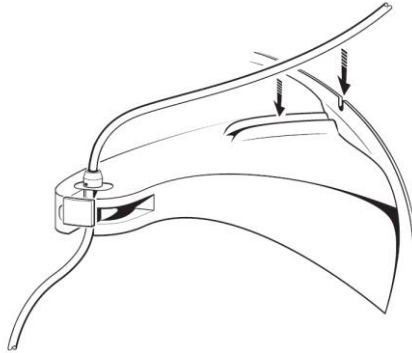

Figure 11. Place tubing in notch on centrifuge ridge.

9. Prepare the syringe pumps on the front of the instrument by rotating the plunger drivers to the open position (see Figure 12a), while sliding them to the lowest points (see Figure 12b).

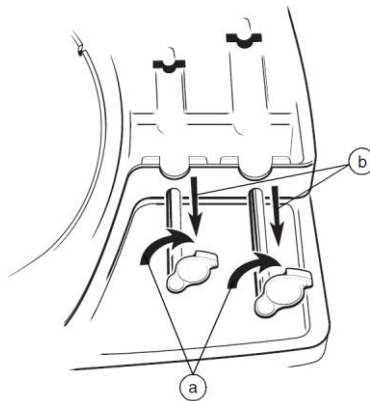

Figure 12. Within the syringe receptacles, slide the open plunger drivers to the lowest points.

10. Prepare the patient for venipuncture according to standard clinical practice using the IV Site Prep Kit, if necessary.
11. Using aseptic technique, draw the appropriate volume of anticoagulant from the ACD-A anticoagulant bag into syringe 2 (60-mL syringe) using the 18-gauge needle. Refer

to Table 1 for the appropriate volumes of ACD-A and blood.

Table 1. Volumes of ACD-A and corresponding volumes of blood to achieve anticoagulated Blood containing ~ 7 parts blood: 1 part ACD-A.

Total Volume of Anticoagulated Blood (mL)	Volume of ACD-A (mL)	Volume of Blood Drawn (mL)
30	4.0	26.0
40	5.0	35.0
50	6.0	44.0
60	8.0	52.0

Caution: Do not use the ACD-A anticoagulant unless the solution is clear, and the seal is intact. Do not reuse the ACD-A supplied in the kit except for multiple separation cycles with the same patient. Discard unused portion.

Note: Alternative methods can be used to collect patient blood. As appropriate, disregard references to the needle and IV tubing.

- Using the needle and IV tubing, slowly draw 2 to 3 mL of patient blood into the 5 mL syringe.
- Disconnect the 5-mL syringe from the IV tubing and discard the syringe.
- Attach syringe 2 to the IV tubing and slowly draw the appropriate volume of patient blood. Gently mix with ACD-A for thorough distribution. Refer to Table 1 for the appropriate volumes of ACD-A and blood.

Note: A minimum volume of 30-mL of blood and ACD-A mixture is required for processing.

Note: Do not exceed 60 mL total volume. Volume in excess of 60 mL may cause an error.

Note: If multiple separation cycles will be performed with the same patient, repeat steps 11 and 14 to prepare and fill syringes.

- Disconnect syringe 2 from the IV tubing. Set aside the syringe and discard the needle and IV tubing utilizing appropriate local procedures.

-
16. Remove the luer connector cap from the shorter length of chamber tubing and attach syringe 1 (10 mL syringe, see Figure 13a).
 17. Evacuate all air from syringe 1 into the chamber tubing line.
 18. Place syringe 1 into the appropriate syringe pump receptacle.
 19. Rotate and slide the plunger driver to engage the syringe 1 plunger (see Figure 13b).
 20. Ensure whole blood is thoroughly mixed using gentle agitation prior to placing in the syringe pump receptacle.
 21. Remove the luer connector cap from the longer length of chamber tubing and attach syringe 2 (see Figure 13c).
 22. Evacuate all air from syringe 2 into the chamber tubing line.

Note: Failure to remove air from syringes may compromise the quality of the product.

23. Place syringe 2 into the appropriate syringe pump receptacle.
24. Rotate and slide the plunger driver to engage the syringe 2 plunger (see Figure 13d).

Caution: Make certain all tubing is free of any kinks, twists, or flat areas.

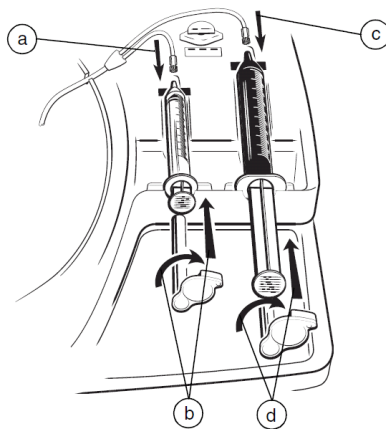

Figure 13. Attach tubing, load syringes, and engage syringe plunger drivers.

-
25. Gently stretch the tubing attached to syringe 2 and slide it completely into pinch valve opening (see Figure 14).

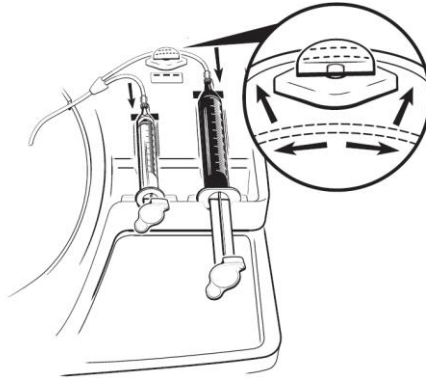

Figure 14. Stretch syringe 2 tubing and slide into pinch valve.

26. When closing the centrifuge and syringe cover, use the heel of the hand to push downwards on the arrows located towards the end of the cover (see Figure 15a). Once the covers have been appropriately closed, there will be a locking sound. Confirm that all indicator lights are green (see Figure 15b).

Note: Do not attempt to force either the centrifuge or syringe covers shut.

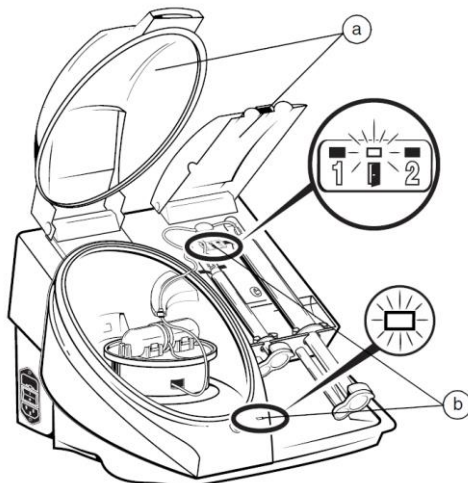

Figure 15. Close centrifuge and syringe covers and confirm green indicator lights.

User Options

PPP Collection

If the user intends to collect platelet poor plasma (PPP), the user should select the PPP collection option at any time after the start key has been pressed and prior to the completion of the collecting phase.

Note: Pressing the PPP key prior to the start key can result in the PPP option timing out and consequently, PPP collection will not occur.

Pressing the [PPP] key will cause the key to be lit, indicating selection of the PPP collection option. Pressing the [PPP] key while it is lit will turn the PPP collection option off. PPP option will require an additional empty 60-mL syringe.

Selecting the PPP collection option will allow the user to remove syringe 2 containing red blood cells after the collecting phase is complete and attach an empty 60-mL syringe for automated delivery of PPP.

Multiple Cycles

If the user intends to perform multiple separation cycles with the same patient blood, the separation chamber and associated tubing can be used for up to three complete separation cycles. Additional 10-mL and 60-mL syringes are required.

Manual Pause

If the user needs to pause the instrument, this can be done by opening the syringe cover. This manual pause option can only be initiated when the centrifuge is spinning at the lower speed used during operation of the syringe pumps.

During this pause the syringe pumps and the timer will become inactive and the centrifuge will continue to spin at the lower speed. The cycle will resume when the user closes the syringe cover and presses the **[START]** key.

Notes

- If the user opens the syringe cover when the instrument is spinning at a high speed, the cycle will continue, and the instrument will not pause until the centrifuge slows to the lower speed.

-
- If the user fails to restart the cycle within ten minutes of initiating the pause, the centrifuge will stop. To resume, press the **[START]** key (Resume operation only applies to software version 3.0 and higher).

Instrument Operation

Program Selection

Note: Program selection options only apply to software version 3.0 and higher.

Before a cycle is initiated, special operating programs may be selected by putting the instrument into “Menu Mode.” The programs that can be selected are:

- **PURGE:** Use to immediately purge blood out of the centrifuge into the 60-mL syringe. Once the centrifuge is purged, the unit returns to the previously selected mode (either STANDARD or MIN. RBC).
- **Purge Instructions**
 1. Power **[OFF]** MAGELLAN.
 2. Use empty 60-mL syringe.
 3. Power **[ON]** MAGELLAN.
 4. Press (-) Key until you see **[OPTIONS]**.
 5. Press the (Arrow) Key to select **[PURGE]**.
 6. Press **[START]**.
 7. When display reads **[READY]** restart your process.
- **MIN. RBC:** Increases removal of blood cells from tubing in order to minimize red blood cells in subsequent cycles. This mode is signified by the text “– RBC” on line 2 of the display.

Note: When using this program, all cellular content will be slightly less than the standard program and cycle time will be shortened to approximately 10 minutes.

- **STANDARD:** The normal, general purpose operating mode. In order to select one of the programs using the Menu Mode, do the following:
 1. Before a cycle has been initiated, continually press the **minus [-]** key until “OPTIONS” is displayed on line 2.
 2. Press the **[START]** key.

-
3. Use the **plus [+]** and **minus [-]** keys to scroll through the options described above.
 4. When the desired option is visible, press the **[START]** key.

Changing the Default Program

Note: Program selection options only apply to software version 3.0 and higher.

The following steps should be followed to change the program that is set by default when the unit is powered on.

- With the unit powered off, press, and hold the **[PPP]** and **plus [+]** keys.
- While continuing to press the keys, power on the unit.
- Use the **plus [+]** and **minus [-]** keys to scroll through the programs.
- When the desired default program is visible, press the **[START]** key.

The program selected will now be the default program for subsequent processing.

Note: PRP Volume Selection: The user must select the volume of platelet rich plasma (PRP) to be collected in syringe 1 by pressing the volume indicator keys on the front of the instrument. The volume selected will be displayed on the message screen and the default volume of PRP is set at 0 mL (The user must indicate a volume between three (3) and ten (10) mL before the instrument will begin a cycle).

Cycle Initiation

When the separation chamber and both syringes are properly installed, PRP volume has been selected, and both covers are closed, the user should press the **[START]** key.

Note: The instrument timer will indicate the approximate amount of time left in the cycle. The timer will begin when the user presses **[START]**. The Arteriocyte Medical Systems MAGELLAN® Autologous Platelet Separator instrument will go through the following phases:

Filling

The Platelet Separator instrument will pump blood mixed with anticoagulant from syringe 2 into the separation chamber. The message **[FILLING]** will appear on the message screen.

Processing

When the chamber is full, the instrument will proceed with the red blood cell (RBC) separation and platelet separation. The message **[PROCESSING]** will appear on the message screen.

Collecting

During the collection phase, the instrument will pump the desired amount of PRP into syringe 1 and the message **[COLLECTING]** will appear on the message screen.

(Optional) PPP Collection

Note: At the end of the collecting phase, the user has the option to collect platelet poor plasma (PPP) into an alternate syringe.

1. If the user has pressed the **[PPP]** key after the start key has been pressed earlier in this cycle, the instrument will automatically pause and prompt the user to change the syringe. During this phase the **[START]** key will be blinking.

Note: Pressing the PPP key prior to the start key can result in the PPP option timing out and consequently, PPP collection will not occur.

2. Open the syringe cover.
3. Disconnect syringe 2 from the chamber tubing.
4. Attach an empty 60-mL syringe to the chamber tubing, place the syringe into the receptacle, and engage the plunger driver around the syringe base.
5. Close the syringe cover.
6. Press the **[START]** key to complete the cycle.

Note: The cycle timer will pause during the PPP collection phase and restart again when the user presses [START]. If the user fails to restart the cycle within ten (10) minutes of initiating the pause, the centrifuge will stop. To resume, press the [START] key.

Emptying

During the emptying phase, platelet poor plasma (PPP) will be automatically emptied into syringe 2, and the message **[EMPTYING]** will appear on the message screen.

When the emptying phase is complete, the centrifuge and syringe pump will stop. The message **[CYCLE COMPLETE]** will appear on the message screen.

Cycle Completion

At the completion of a cycle, the instrument will display the message **[+ = CONTINUE / - = CLEAR TOTAL/CYCLE COMPLETE]**.

No Additional Cycles

If no additional cycles will be run with the same patient, the user should press the **minus [-]** key to clear the PRP totals.

Multiple Cycles with the Same Patient Blood

If additional cycles will be run with blood from the same patient, the user can press the **plus [+]** key indicating that cumulative PRP volumes from multiple cycles of the same patient blood should be calculated and displayed.

This cumulative total will appear in the lower left side of the message screen at the end of the individual cycle.

- To begin another cycle:
 1. Attach and load new syringes. Refer to steps 9 through 26 of the instructions for use, as appropriate.
 2. Close syringe cover.
 3. Select desired volume of PRP and press the **[START]** key.

When the final cycle is complete, luer connector caps should be replaced on chamber tubing. The tubing, separation chamber, and other blood contact materials should be appropriately disposed of according to appropriate biohazard waste procedures.

TROUBLESHOOTING

System Errors

During a system error an audible alert will sound, and the following information will be displayed on the screen:

1. A reference number for the technical service representative.

-
2. The failure location.
 3. Appropriate user response.

If the user is not able to resolve the issue from the information displayed on the screen and the troubleshooting guide, they should contact their service representative at (866)-660-2674 and provide the reference number.

The user should also take note of relevant information about the error. This information is helpful to troubleshoot the device and may lead to a resolution over the phone.

Record the following:

1. Serial number.
2. Cycles.
3. Reference (error) number.
4. The failure location and when it occurred.
5. User response already taken.
6. Any other information deemed relevant, such as:
 - a. Type of draw.
 - b. Volume.
 - c. Presence of clots.
 - d. Type of procedure.
 - e. Needle Size used.

Information should be retained to allow a technical service representative to properly assist the user.

User Intervention Conditions

When user intervention is required, an audible alert will sound, and the following information will be displayed on the screen:

1. The suggested user action.
2. A direction to restart [**PRESS START**].

The user should follow the instructions provided in the message. Details regarding user intervention messages are provided in Table 2.

Note: Message wording may vary slightly on older software versions.

Table 2. Conditions requiring user intervention.

Message	Explanation	Response
<p>[CLOSE COVERS] [PRESS START]</p>	<p>The message will appear if either one of the covers is not completely closed or latched.</p>	<p>Make certain that the centrifuge cover and the syringe cover are both completely latched. Confirm that all sensor lights are green. Press the (START) key.</p>
<p>[LOAD SYRINGES] [PRESS START]</p>	<p>The message will appear if either of the syringes is not accurately attached to the chamber tubing or is incorrectly placed in the syringe pump receptacles. A red sensor light will indicate the failure area.</p>	<p>Check syringes 1 and 2 and tubing connections. Confirm that all sensor lights are green. Press (START) Key.</p>
<p>[ENTER VOLUME] [PRESS START]</p>	<p>This message will appear if the PRP volume remains at the default volume (0 mL). A volume must be entered.</p>	<p>Enter a PRP volume. Press the [START] key.</p>
<p>[LOAD SYSTEM] [ENTER VOLUME] [PRESS START]</p>	<p>This message will appear if either of the covers is not completely closed or latched. A red sensor light will appear at the failure area.</p>	<p>Check syringe 1 and syringe 2. Check centrifuge cover and syringe cover. Enter PRP volume. Press the [START] key.</p>
<p>[CHECK OPTICS] [PRESS START]</p>	<p>This message will appear if the separator sensor did not calibrate.</p>	<p>Check for obstructions, dirt, or damage to the optical components. Press the [START] key.</p>

Message	Explanation	Response
[CHECK CENTRIFUGE] [RECLOSE COVER] [PRESS START]	This message will appear if the centrifuge door latch will not lock properly.	Open and close the cover, making sure it latches properly. Press the [START] key.
[CHECK TUBING] [PRESS START]	This message will appear if the pinch valve is not operating correctly. It is sometimes caused by the tubing not properly seated in the pinch valve.	Re-seat the tubing in the pinch valve. Press the [START] key.

Error Conditions		
[ERROR-2]	This message will appear if the initial software test did not pass. It is often caused by an internal software error.	Call Customer Service at (866)-660-2674.
[ERROR-4] [CHECK SYRINGE VOLUME] [PRESS START]	This message will appear if the unit cannot detect a clear light path of the sensor after attempting to empty the chamber. It is often caused by too much blood being left in the chamber from a previous cycle or overfill of the 60-mL syringe.	Visually inspect the chamber to check for blood. If blood is seen, attach an empty 60-mL syringe and purge the chamber. Replace the 60-mL syringe filled with blood and try running the cycle again. If the problem persists, call service.

Error Conditions		
<p>[ERROR-5] [CHECK PINCH VALVE]</p>	<p>This message will appear if the pinch valve is not operating correctly. It is sometimes caused by the tubing not being properly seated in the pinch valve.</p>	<p>Re-seat the tubing in the pinch valve. Press the [START] key. If the problem persists, call service.</p>
<p>[ERROR-6] [CHECK DISPOSABLE INSTALLATION]</p>	<p>This message will appear if the unit's optics are not able to detect a light path running through the disposable. It may sometimes be caused by the disposable not being properly seated in the centrifuge</p>	<p>Open the centrifuge cover and re-seat the disposable, making sure it is fully seated in both ends of the centrifuge caddy. If required, clean optical lenses and pathways. Close the cover and press the [START] key. If problem persists, call service.</p>
<p>[ERROR-7] [NO RBC INTERFACE]</p>	<p>This message will appear if the unit is not able to detect the RBC interface. It may occur if clotted blood is in the chamber or if the 60-mL syringe plunger is not properly seated in the plunger driver.</p>	<p>Visually inspect chamber for possible clotted blood. If blood has clotted, a new sample will need to be taken. Check 60-mL syringe plunger to be sure it is properly seated in plunger driver. If it was not seated properly, purge the chamber, and restart the cycle. If neither of the above conditions apply, call service.</p>

Error Conditions		
[ERROR-10] [CHECK CENTRIFUGE COVER]	This message will appear if the centrifuge door does not remain latched during cycle	Open and close the cover, making sure it latches properly. Purge the chamber if necessary. Press the [START] key to try running another cycle. If the problem persists, call service.
[ERROR-11 OR 12]	This message will appear if the 60mL syringe has stalled. This may occur if there is a possible blood clot.	Run purge cycle and restart machine. If there is a clot, a new blood draw and disposable will be needed.
[ERROR-13 OR 14]	This message will appear if the 10-mL syringe has stalled. This may occur if there is a possible blood clot.	Run purge cycle and restart machine. If there is a clot, a new blood draw and disposable will be needed.
[Message-750 Cycles]	This message will appear if the machine has run 750 cycles and is due for service.	Have machine serviced. Call (866)-660-2674 to arrange service.
Syringe pump “clicking”	This message may appear if the syringe pump movement is being blocked. This may occur if the tubing is blocked, pinched or there is a clot present.	Verify routing and position of tubing and restart machine. Run purge cycle. If there is a clot, a new blood draw and disposable will be needed.

Error Conditions		
<p>Blood clot in tubing or separation chamber</p>	<p>This message may appear if a blood clot formed during the separation cycle. This may occur if there is a traumatic phlebotomy, insufficient ACD-A, and inappropriate mixing of blood.</p>	<p>New blood draw and disposable will be needed.</p>
<p>PPP key pressed, system did not produce PPP</p>	<p>PPP key is pressed but PPP pause does not occur, and plasma is dispensed into the RBC waste syringe.</p>	<p>The PPP key must be pressed after the Start key to ensure that the PPP option does not time out. OR Ensure that the tubing is seated completely into the white pinch valve at the top of the syringe housing on the right side of the machine. Once both of these items have been verified, if any fluid remains in the centrifuge, purge the system then waste RBC syringe can be re-spun to collect PPP utilizing a new 10 mL syringe and selecting 3 mL PRP. This 3 mL PRP will be waste.</p>

Stopped Timer

The approximate amount of time remaining in a single cycle will appear on the left in the lower line of the message screen.

The timer will stop for one of the following reasons:

- The instrument is in the pause mode.
- A condition is present which requires user intervention.
- A system error exists.

Except for system error conditions, when the user addresses any interventions and presses **[START]**, the timer will continue and will show the time remaining in that cycle.

Blank Screen

Check the power connections at the source and at the instrument. Check that the ON/OFF switch is turned ON. Contact a service representative.

CLEANING AND SERVICE

CAUTION: BEFORE USING ANY CLEANING OR DECONTAMINATION METHODS EXCEPT THOSE RECOMMENDED BY THE MANUFACTURER, USERS SHOULD CHECK WITH THE MANUFACTURER THAT THE PROPOSED METHOD WILL NOT DAMAGE THE EQUIPMENT.

Cleaning

MAGELLAN® Platelet Separator Instruments should have all accessible surfaces cleaned and disinfected using Hydrogen Peroxide Cleaner Disinfectant Spray (1.4% Hydrogen Peroxide) or equivalent product.

Spray the surfaces of the MAGELLAN® Platelet Separator instrument with Hydrogen Peroxide Cleaner Disinfectant Spray and ensure that the surface is thoroughly wetted for a contact time of 4 minutes. After spraying, wipe the surface with Hydrogen Peroxide wipes and maintain wetness for an additional contact time of 5 minutes. Upon completion of cleaning, verify that all surfaces are visually clean. Repeat the above mentioned cleaning routine to attain disinfection of the device.

Caution: Use of any cleaning disinfection method other than the prescribed routine may not accomplish the required levels of cleanliness and/or disinfect of the surfaces, which may lead to contamination.

Note: The use of isopropyl alcohol to clean the centrifuge and syringe covers may lead to cosmetic cracking.

If it is suspected that fluid has penetrated into the machine, the machine should be unplugged and immediately examined by a trained service or biomedical technician.

Caution: If blood or fluids are spilled, use appropriate universal precautions and engineering controls (such as eye protection, mask, and gloves) to protect yourself from the blood and/or the cleaning fluids.

Periodic Maintenance and Safety Inspection

Maintenance and safety inspections of the platelet separator instrument must be performed at least once every 24 months, or following 750 separation cycles, whichever comes first. This work must be done by persons, who, based on their training, knowledge, and practical experience, are capable of adequately performing such inspections and who do not require additional instructions with regard to the technical and safety inspection.

Warning: If a technical and safety inspection reveals a defect which could cause harm, the device should not be used until it has been properly repaired. The operator must immediately notify the appropriate individuals and Arteriocyte Medical Systems' Service Department of these defects by calling (866)-660-2674 or customerservice@arteriocyte.com.

Service

Arteriocyte Medical Systems maintains a professional staff to provide technical consultation to product users. For more information, contact your local Arteriocyte Medical Systems representative, or contact Arteriocyte Medical Systems at the email address or telephone number listed on the back cover.

The platelet separator instrument has been carefully engineered, manufactured and quality tested to provide long, trouble-free service. Should service or repair be required, contact an Arteriocyte Medical Systems representative at the email address or telephone number listed on the back cover of this manual.

Calibration Services

The preventative maintenance and calibration of the Magellan machine must be performed by Arteriocyte Medical Systems technician. The machine must be sent for preventative maintenance and calibration within the calibration date provided on the machine's back panel or 750 cycles, whichever is earlier.

Note: Ship the Arteriocyte Medical Systems MAGELLAN® Autologous Platelet Separator Instrument back to Arteriocyte Medical Systems in its original shipping container. If the original shipping container is not available, contact your Arteriocyte Medical Systems representative. A serial number identifying each individual device is printed on the back of the device. This serial number should be referenced in any correspondence regarding this device.

Contact Arteriocyte Medical Systems for additional disposable components and accessories. Arteriocyte Medical Systems locations are listed at the back of this manual.

At the end of its useful life, dispose all components of the Arteriocyte Medical Systems MAGELLAN® Autologous Platelet Separator System in accordance with local environmental requirements.

End of Life Disposition



Do not dispose of this product in the unsorted municipal waste stream. Follow local regulations for proper disposal.

INSTRUMENT LIMITED WARRANTY¹ (U.S.)

THE FOLLOWING LIMITED WARRANTY APPLIES TO UNITED STATES CUSTOMERS ONLY:

- A. This LIMITED WARRANTY provides the following assurance to the purchaser of the **Arteriocyte Medical Systems MAGELLAN® Autologous Platelet Separator Instrument**, hereafter referred to as the “Instrument”:
- (1) Should the Instrument fail to function within normal tolerances due to a defect in materials or workmanship within a period of one (1) year, commencing with the delivery of the Instrument to the purchaser, Arteriocyte Medical Systems will at its option: (a) repair or replace any defective part or parts of the Instrument; (b) issue a credit to the purchaser equal to the Purchase Price, as defined in Subsection A (2), against the purchase of the replacement Instrument; or (c) provide a functionally comparable replacement Instrument at no charge.
 - (2) As used herein, Purchase Price shall mean the lesser of the net invoiced price of the original, or current functionally comparable, or replacement Instrument.
- B. To qualify for the repair, replacement or credit set forth in Section A, the following conditions must be met:
- (1) The Instrument must be returned to Arteriocyte Medical Systems within sixty (60) days after discovery of the defect (Arteriocyte Medical Systems may, at its option, repair the Instrument on site).
 - (2) The Instrument must not have been repaired or altered outside of Arteriocyte Medical Systems’ factory in any way which, in the judgment of Arteriocyte Medical Systems, affects its stability and reliability. The Instrument must not have been subjected to misuse, abuse, or accident.
- C. This LIMITED WARRANTY is limited to its express terms in particular:
- (1) Except as expressly provided by this LIMITED WARRANTY, ARTERIOCYTE MEDICAL SYSTEMS IS NOT RESPONSIBLE FOR ANY DIRECT, INCIDENTAL OR CONSEQUENTIAL DAMAGES BASED ON ANY DEFECT,

FAILURE OR MALFUNCTION OF THE INSTRUMENT, WHETHER THE CLAIM IS BASED ON WARRANTY, CONTRACT, TORT OR OTHERWISE.

(2) This LIMITED WARRANTY is made only to the purchaser of the Instrument. AS TO ALL OTHERS, ARTERIOCYTE MEDICAL SYSTEMS MAKES NO WARRANTY, EXPRESS OR IMPLIED, INCLUDING, BUT NOT LIMITED TO, ANY IMPLIED WARRANTY OF MERCHANTABILITY, OR FITNESS FOR A PARTICULAR PURPOSE WHETHER ARISING FROM STATUATE, COMMON LAW, CUSTOM OR OTHERWISE. NO EXPRESS OR IMPLIED WARRANTY TO THE PATIENT SHALL EXTEND BEYOND THE PERIOD SPECIFIED IN A (1) ABOVE.

THIS LIMITED WARRANTY SHALL BE THE EXCLUSIVE REMEDY AVAILABLE TO ANY PERSON.

(3) The exclusions and limitations set out above are not intended to and should not be construed so as to contravene mandatory provisions of applicable law. If any part or term of this LIMITED WARRANTY is held to be illegal, unenforceable or in conflict with applicable law by a court of competent jurisdiction, the validity of the remaining portions of the LIMITED WARRANTY shall not be affected, and all rights and obligations shall be construed and enforced as if this LIMITED WARRANTY did not contain the particular part or term held to be invalid. This LIMITED WARRANTY gives the purchaser specific legal rights. The purchaser may also have other rights which vary from state to state.

(4) No person has any authority to bind Arterioocyte Medical Systems to any representation, condition, or warranty except this LIMITED WARRANTY.

¹ This Limited Warranty is provided by Arterioocyte Medical Systems, Inc., 45 South Street, Hopkinton, MA 01748. It applies only in the United States. Areas outside the United States should contact their local Arterioocyte Medical Systems representative for exact terms of the Limited Warranty.

DISPOSABLES KIT LIMITED WARRANTY² (U.S.)

THE FOLLOWING LIMITED WARRANTY APPLIES TO UNITED STATES CUSTOMERS ONLY:

- A. This Limited Warranty provides the following assurance to the customer who receives the Arterioocyte Medical Systems' MAGELLAN[®] Autologous Platelet Separator Disposables Kit, hereafter referred to as the "Product":
- (1) Should the Product fail to function within normal tolerances due to a defect in materials or workmanship prior to its "Use Before Date", Arterioocyte Medical Systems will at its option: (a) issue a credit equal to the Purchase Price, as defined in Subsection A (2), against the purchase of the replacement Product or (b) provide a functionally comparable replacement Product at no charge.
 - (2) As used herein, Purchase Price shall mean the lesser of the net invoiced price of the original, or current functionally comparable, or replacement Product.
- B. To qualify for the Limited Warranty, these conditions must be met:
- (1) The Product must be used prior to its "Use By" date.
 - (2) The unused portion of the Product must be returned to Arterioocyte Medical Systems within 60 days after use and shall be the property of Arterioocyte Medical Systems.
 - (3) The Product must not have been altered or subjected to misuse, abuse, or accident.
 - (4) The Product may not have been used by any other customer.
- C. This Limited Warranty is limited to its express terms. In particular:
- (1) Except as expressly provided by this Limited Warranty, ARTERIOCYTE MEDICAL SYSTEMS IS NOT RESPONSIBLE FOR ANY DIRECT, INCIDENTAL OR CONSEQUENTIAL DAMAGES BASED ON ANY DEFECT, FAILURE OR MALFUNCTION OF THE PRODUCT, WHETHER THE CLAIM IS BASED ON WARRANTY, CONTRACT, TORT OR OTHERWISE.
 - (2) This Limited Warranty is made only to the customer in whom the Product was used. AS TO ALL OTHERS,

ARTERIOCYTE MEDICAL SYSTEMS MAKES NO WARRANTY, EXPRESS OR IMPLIED, INCLUDING, BUT NOT LIMITED TO, ANY IMPLIED WARRANTY OF MERCHANTABILITY, OR FITNESS FOR A PARTICULAR PURPOSE WHETHER ARISING FROM STATUTE, COMMON LAW, CUSTOM OR OTHERWISE. NO EXPRESS OR IMPLIED WARRANTY TO THE CUSTOMER SHALL EXTEND BEYOND THE PERIOD SPECIFIED IN A (1) ABOVE.

LIMITED WARRANTY SHALL BE THE EXCLUSIVE REMEDY AVAILABLE TO ANY PERSON.

(3) The exclusions and limitations set out above are not intended to and should not be construed so as to contravene mandatory provisions of applicable law. If any part or term of this Limited Warranty is held to be illegal, unenforceable or in conflict with applicable law by a court of competent jurisdiction, the validity of the remaining portions of the Limited Warranty shall not be affected, and all rights and obligations shall be construed and enforced as if this Limited Warranty did not contain the particular part or term held to be invalid. This Limited Warranty gives the customer specific legal rights. The customer may also have other rights which vary from state to state.

(4) No person has any authority to bind Arterioocyte Medical Systems to any representation, condition, or warranty except this Limited Warranty.

² This Limited Warranty is provided by Arterioocyte Medical Systems, Inc., 45 South Street, Hopkinton, MA 01748. It applies only in the United States. Areas outside the United States should contact their local Arterioocyte Medical Systems representative for exact terms of the Limited Warranty.

EC DECLARATION OF CONFORMITY

Arteriocyte Medical Systems, Inc., declares the medical instrument known as:

MAGELLAN® Autologous Platelet Separator System
(AMS100, MAG100, TRU100, TRU200, MAG200 and BTI200)

Complies with EN 60601-1-2:2015 for Emission and Immunity.

This declaration applies to CE marked devices produced after the date of issuance of this declaration and before it is either superseded by another declaration or withdrawn.

ARTERIOCYTE

Helping Patients Heal Faster.

Manufacturer:

Arterioocyte Medical Systems, Inc.
45 South Street
Hopkinton, MA 01748
USA

Internet: www.arterioocyte.com
customerservice@arterioocyte.com

Toll-free: 1-866-660-AMSI (2674)
Fax: 508-597-8338